

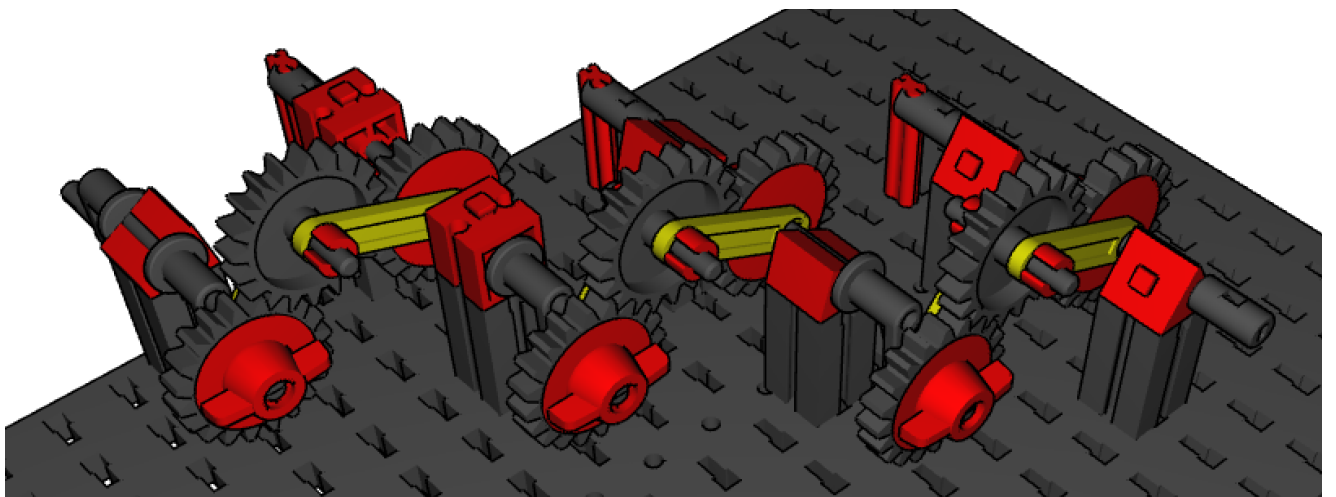

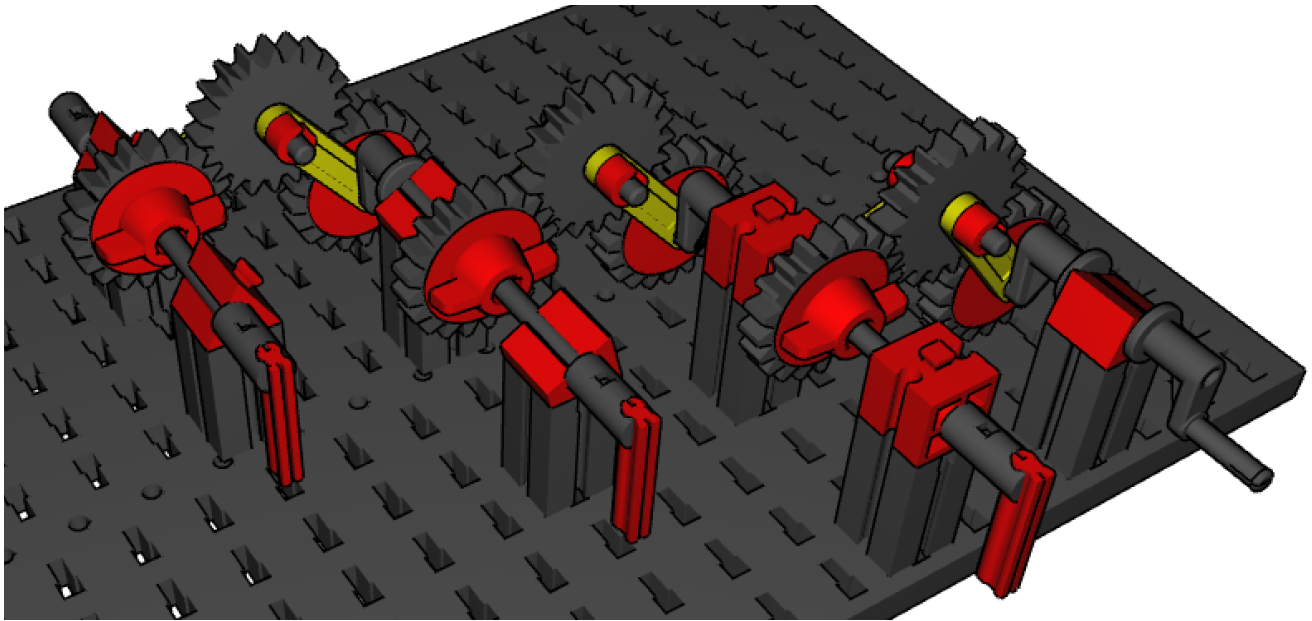







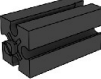

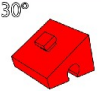



# Mehrstufiges Getriebe mit zyklisch variablem Übersetzungsverhältnis

Wie aus einer gleichförmigen Bewegung eine ungleichförmige wird.

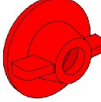

## Einzelteilliste für das Modell

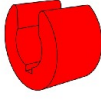
 Grundplatte 258x186	<b>32985</b>  1	 Baustein 15 mit Bohrung	<b>32064</b>  2
 Baustein 30 schwarz	<b>32879</b>  7	 Rastachse 75	<b>35087</b>  3
 Winkelstein 30 Grad	<b>31011</b>  3	 Rastadapter	<b>36227</b>  3
 Rastachse 30	<b>35063</b>  1	 Verbindungsstück 30	<b>31061</b>  3
 Gelenkkurbel	<b>35088</b>  4	 Winkelstein 60 Grad	<b>31010</b>  2
 I-Strebe 30 gelb	<b>31764</b>  6	 Rastkupplung	<b>35073</b>  1
 Flachnabenzange	<b>35031</b>  6		
 Zahnrad Z20	<b>31021</b>  6		
 Nabenmutter mit Scheibe	<b>31058</b>  6		
 Kunststoffachse 30	<b>38413</b>  3		
 Kettenrad Z20	<b>31779</b>  3		
 Klemmbuchse 5	<b>37679</b>  6		



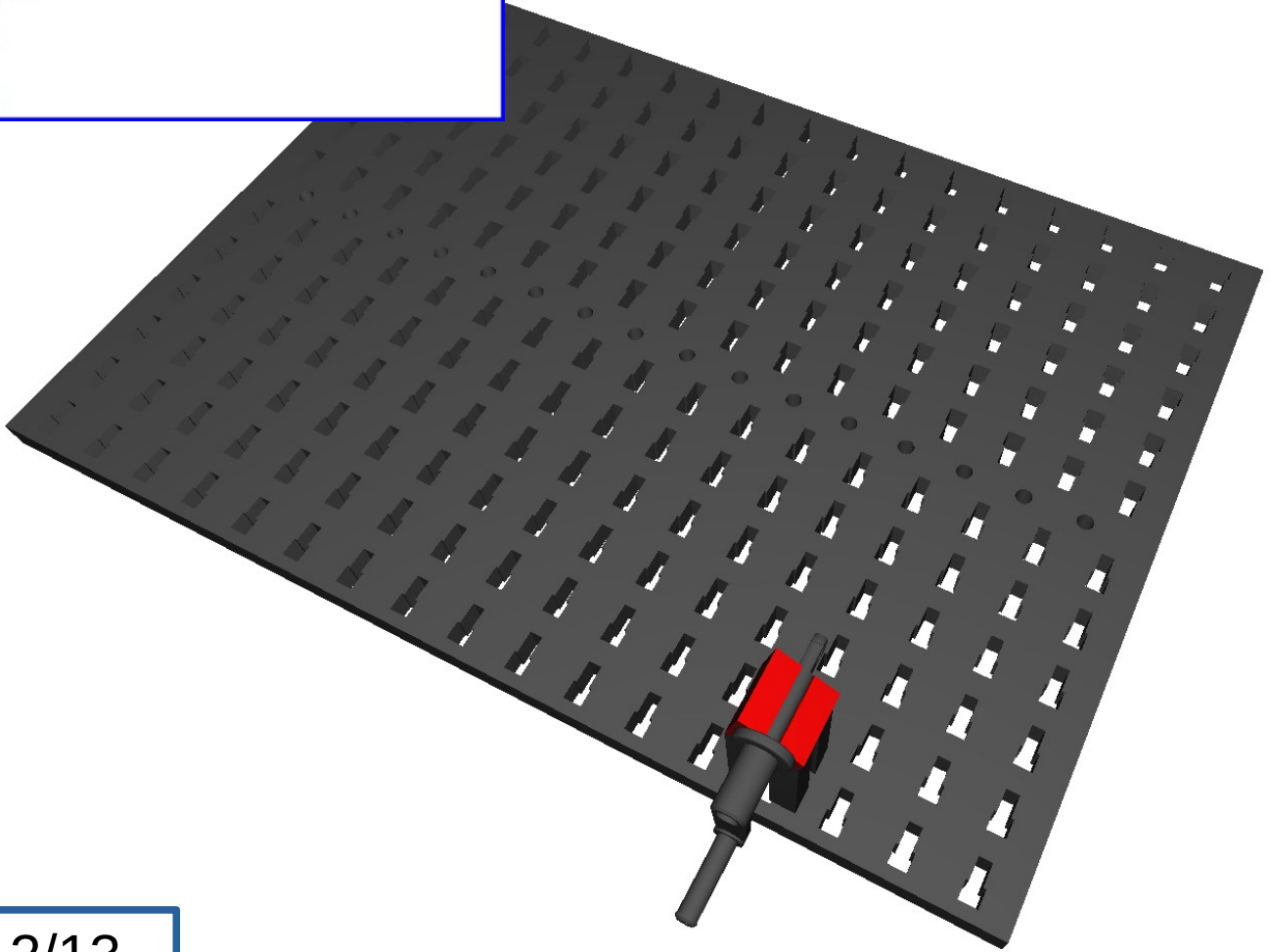
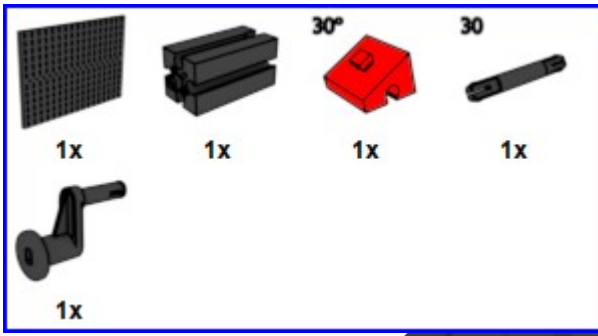

1/13

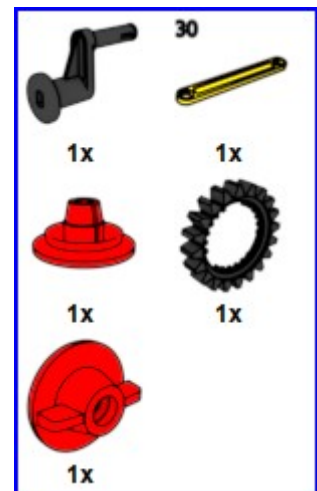
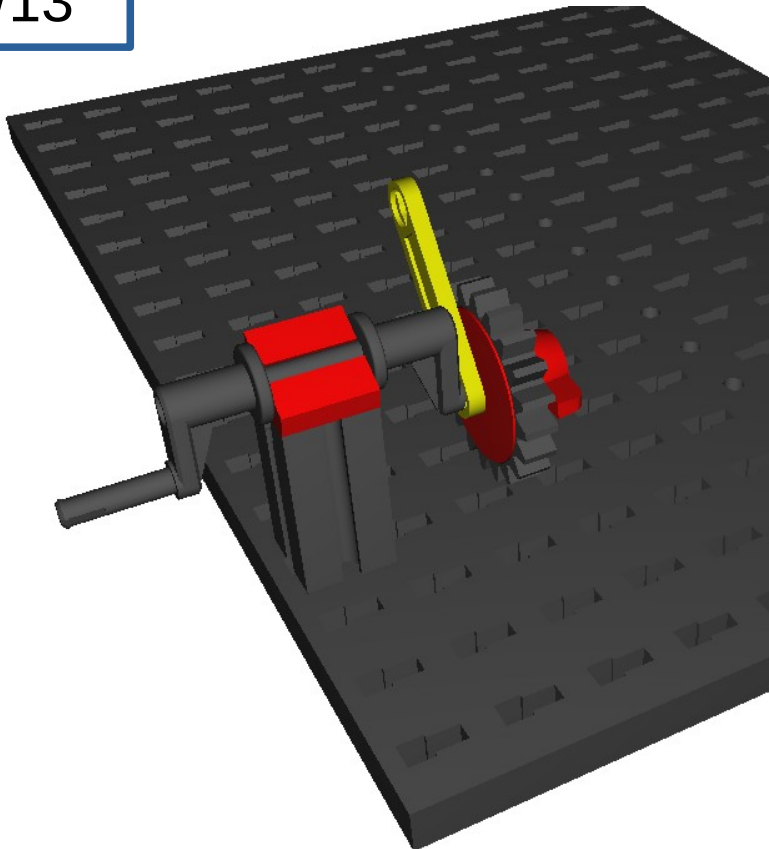

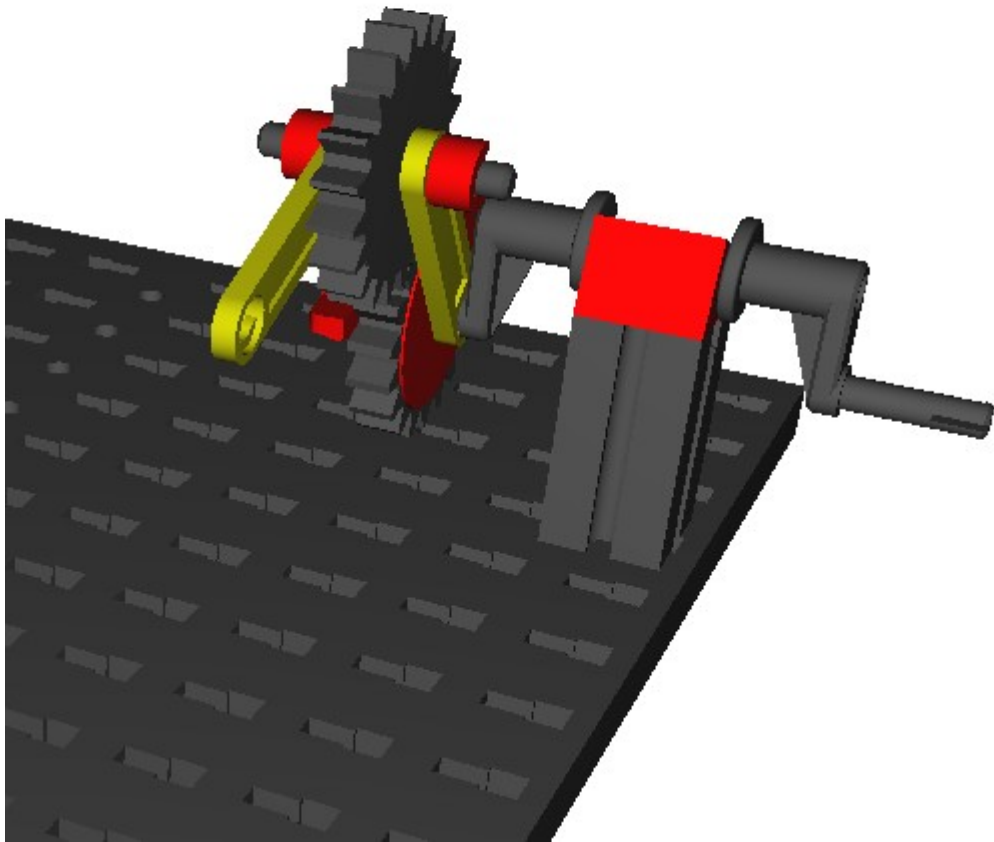
2/13





- 30  1x
- 30  1x
-  1x
-  2x

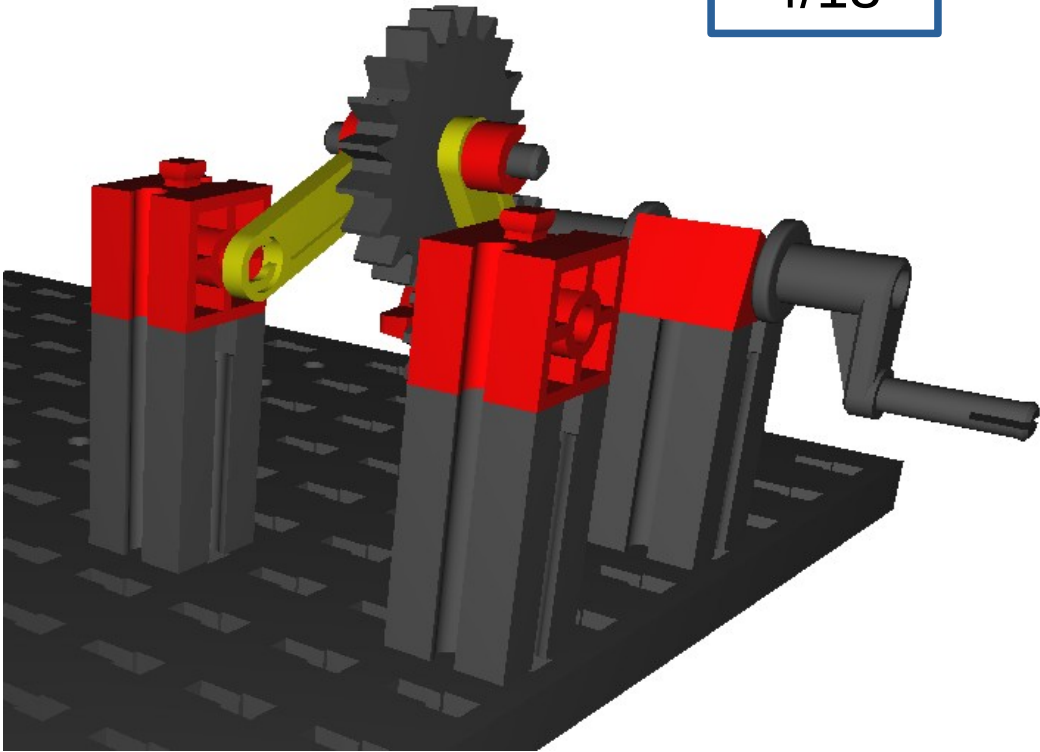

5/13

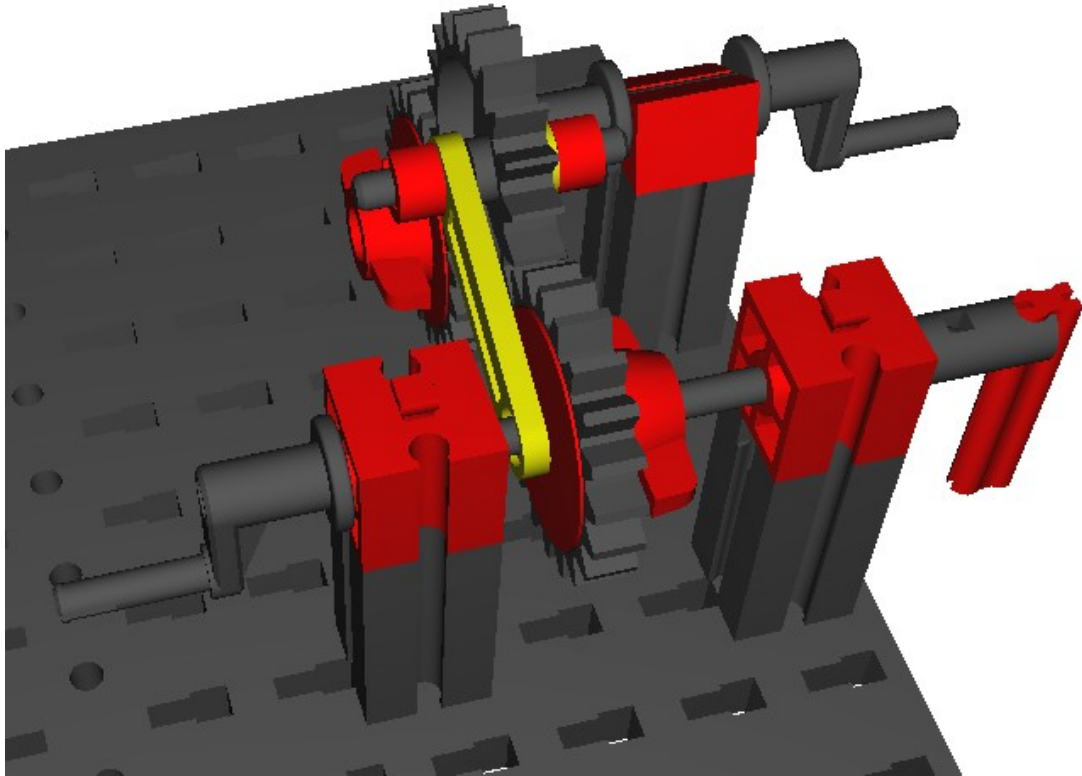

- |    |  |    |
|----|--|----|
| 75 |  |    |
| 1x |  | 1x |
| 30 |  |    |
| 1x |  | 1x |
|    |  |    |
| 1x |  | 1x |
|    |  |    |
| 1x |  |    |

6/13

- |    |  |    |
|----|--|----|
| 30 |  |    |
| 1x |  | 1x |
|    |  |    |
| 1x |  | 1x |

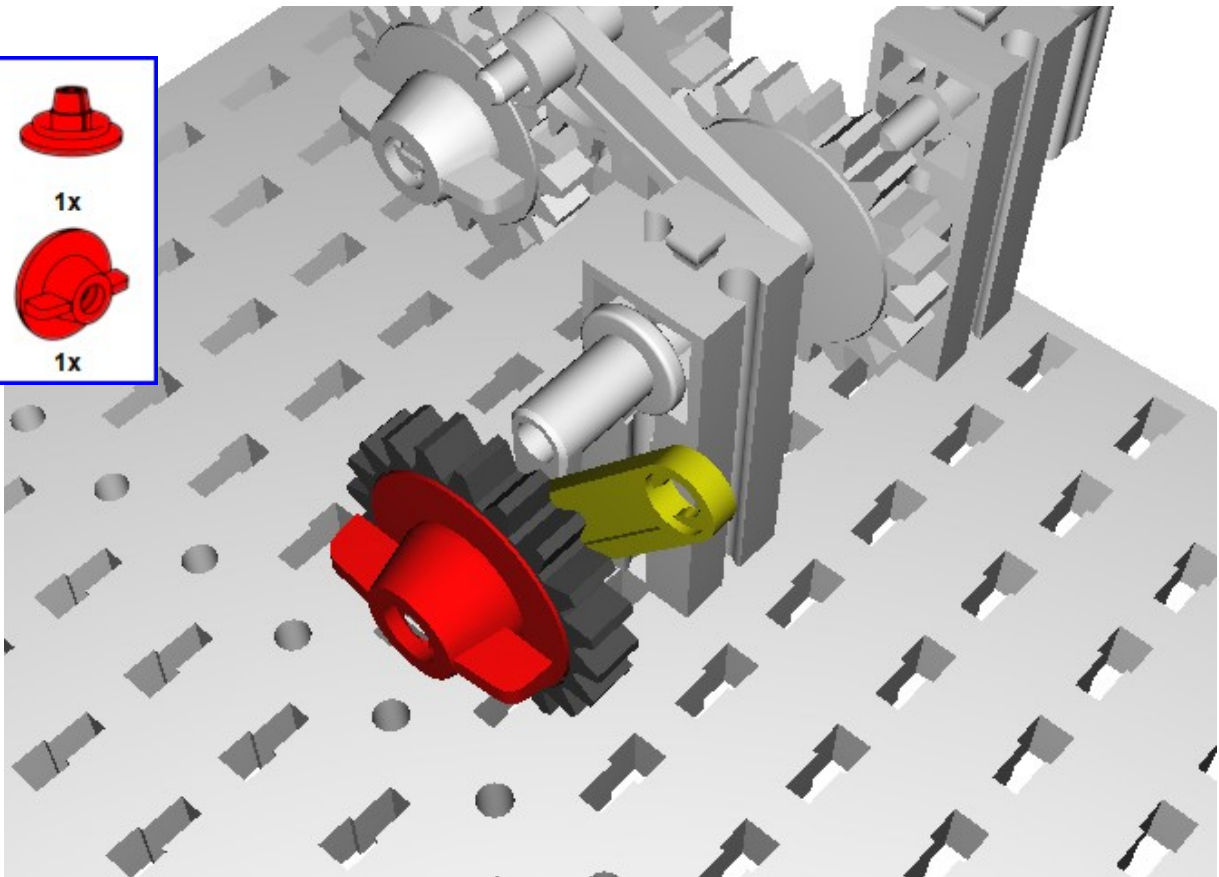

7/13

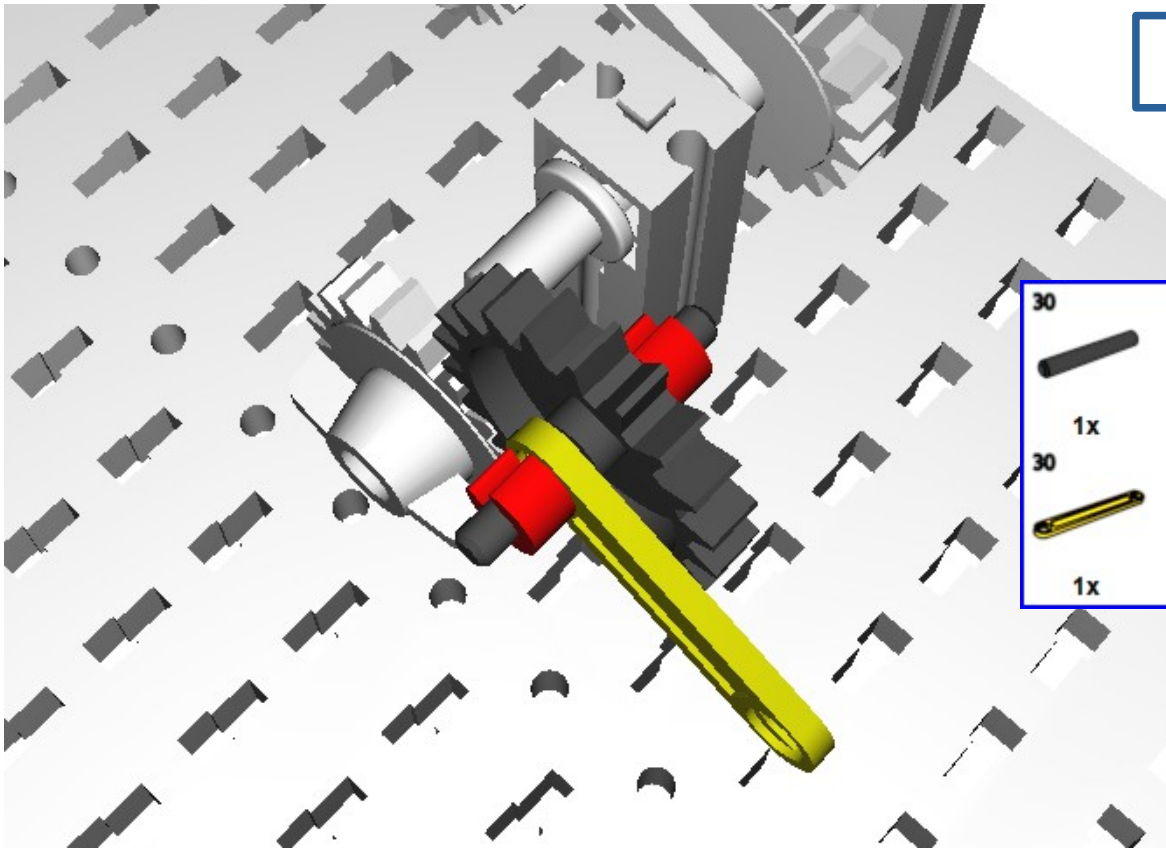

- 30 1x
- 30 1x
- 30 1x
- 1x 2x

8/13

- 2x
- 30° 2x

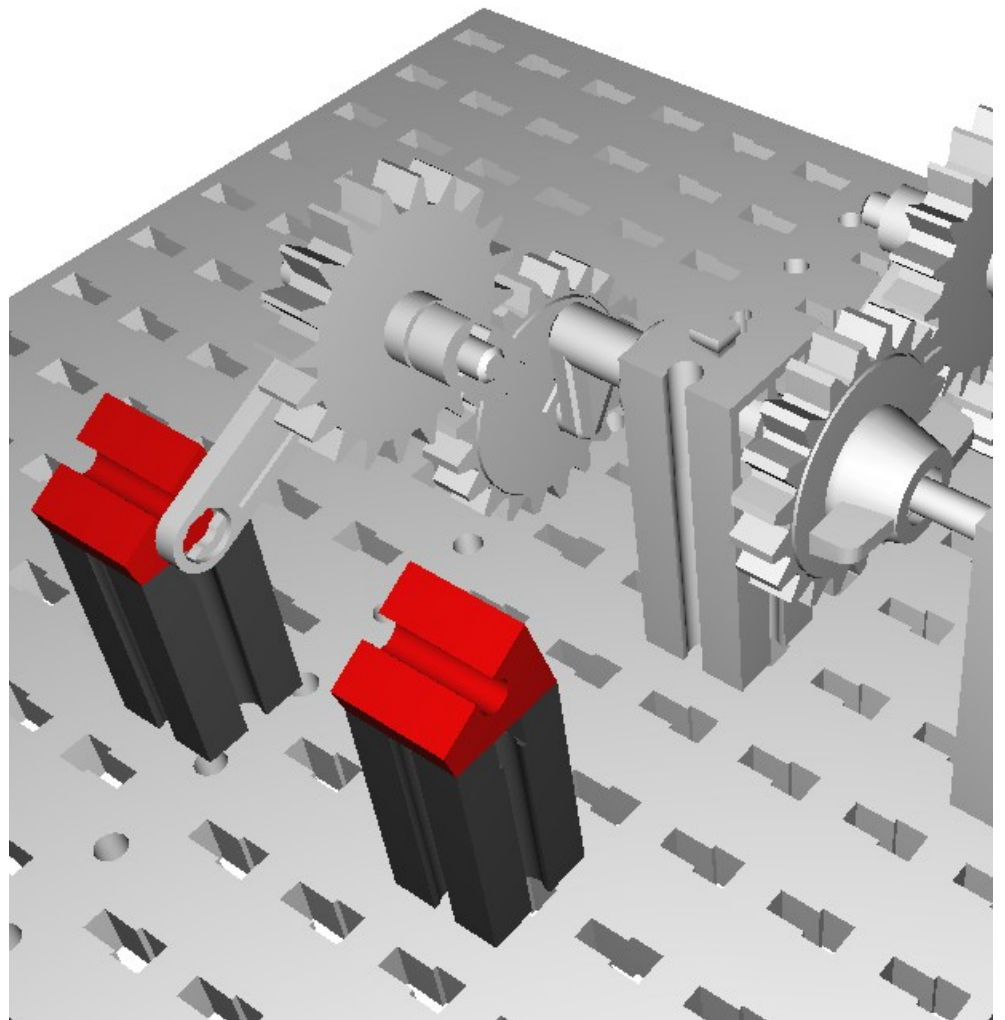

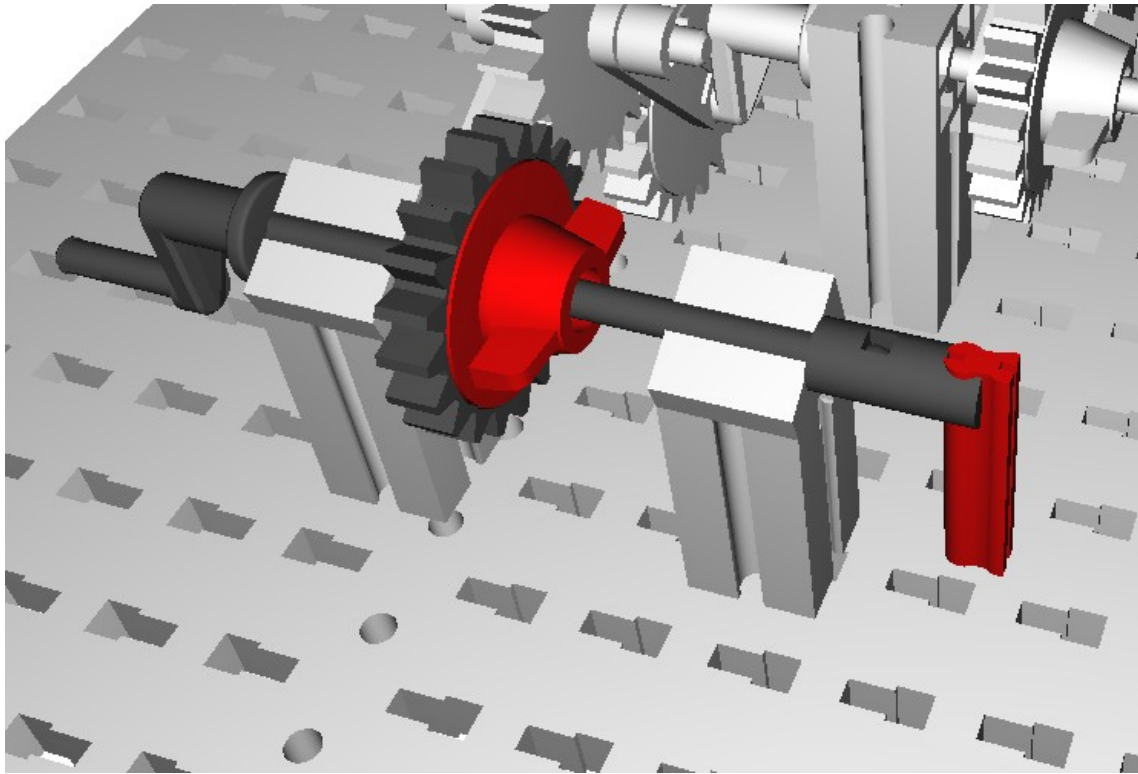

- 75 1x
- 30 1x
- 1x
- 1x
- 1x
- 1x
- 1x

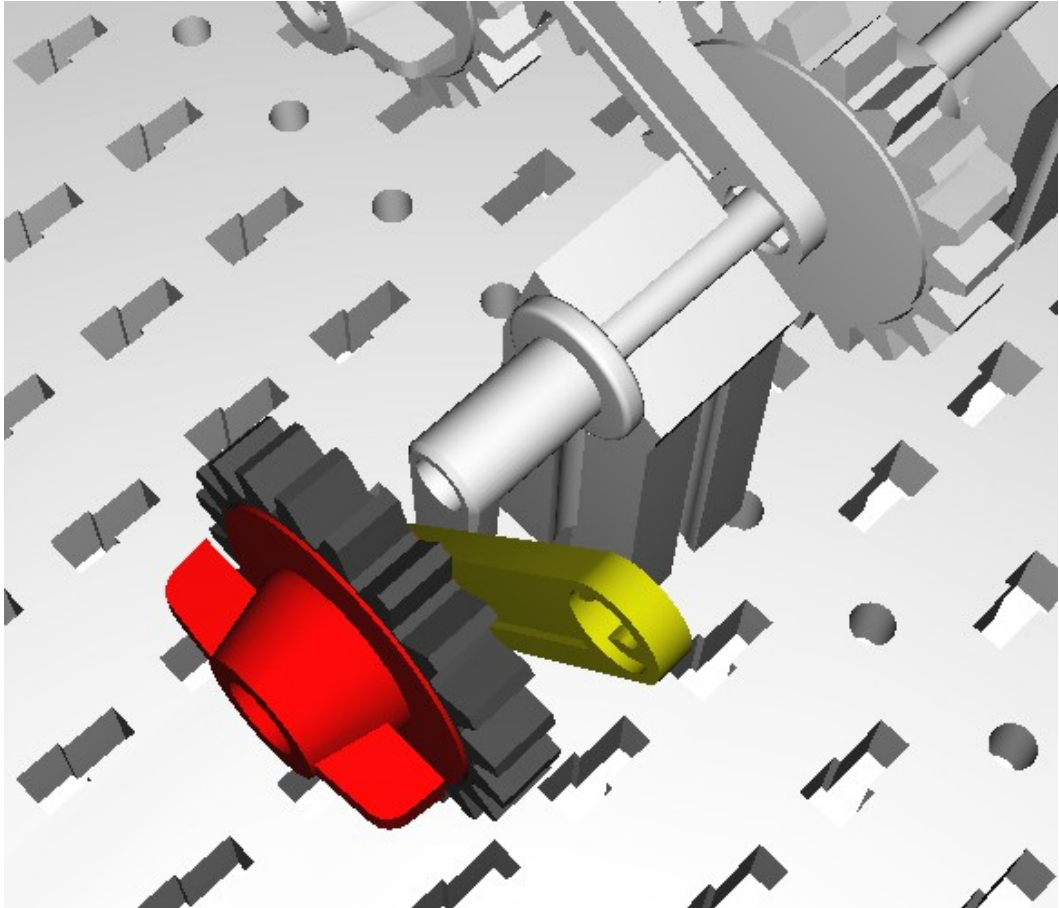

- 30 1x
- 1x
- 1x
- 1x
- 1x

11/13

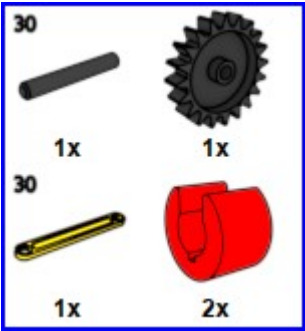
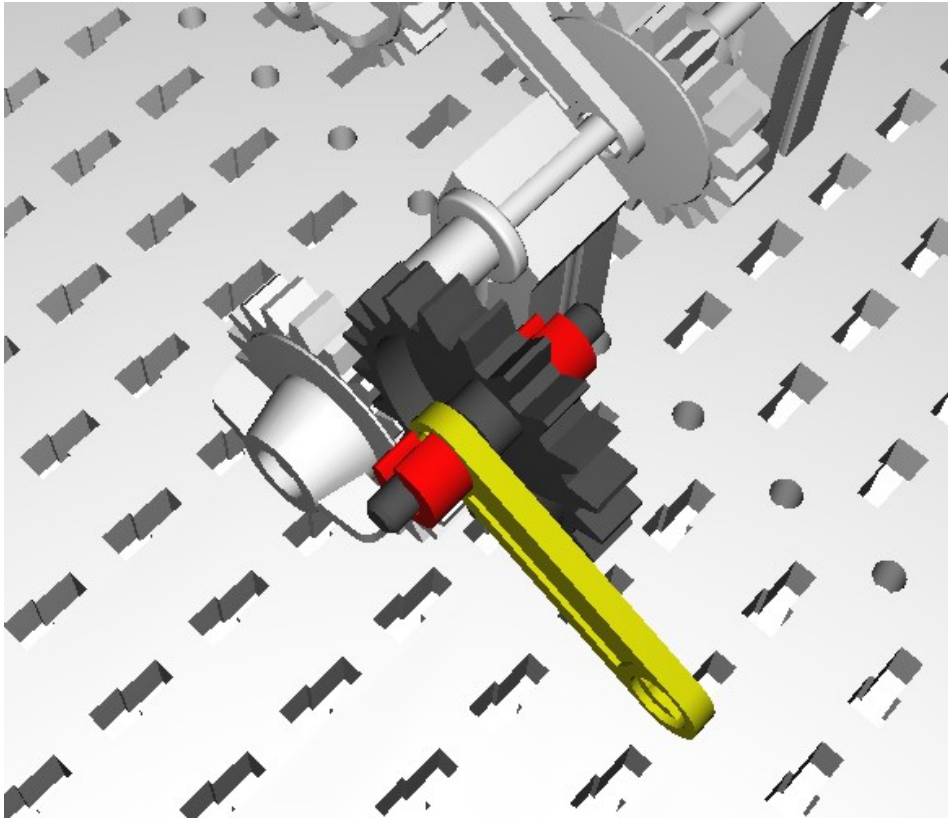

12/13

